

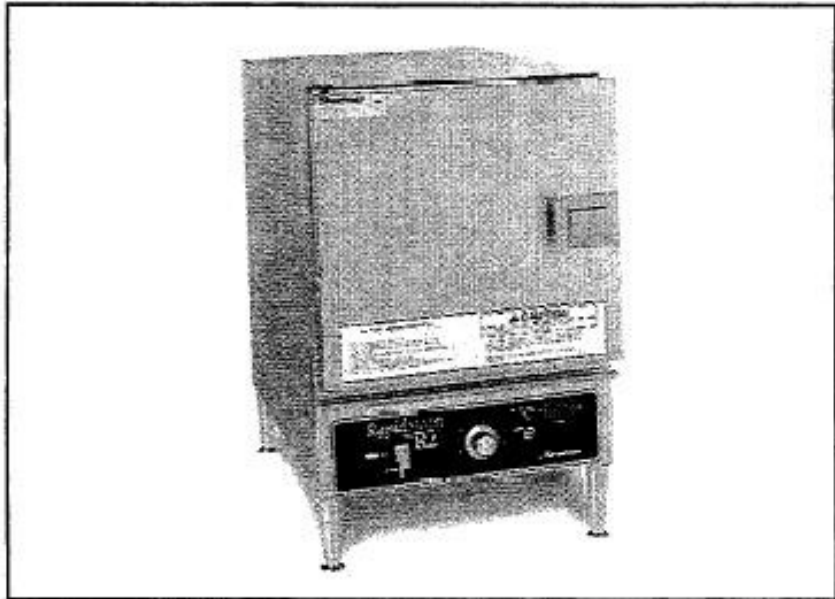

**IMPORTANT**  
**FOR FUTURE REFERENCE**  
Please complete this information  
and retain this manual for the life  
of the equipment.  
MODEL # \_\_\_\_\_  
SERIAL # \_\_\_\_\_  
DATE PURCHASED \_\_\_\_\_

**OPERATOR'S MANUAL**  
INSTALLATION  
OPERATION AND MAINTENANCE INSTRUCTIONS  
*RapidSteam*  
**R2 COUNTERTOP**  
**CONVECTION STEAMER**

**MODEL: R2**



**⚠ WARNING**  
Improper installation, service, or maintenance can cause property damage,  
injury or death. Read the installation, operation and maintenance instructions  
thoroughly before installing and operating this equipment.

**“Our Goal—First Time Fix”**

1100 Old Honeycutt Road • Fuquay-Varina, NC 27526  
(919) 552-9161 • (800) 348-2558  
FAX (800) 910-9915 • FAX (919) 552-8682



**R2 COUNTERTOP CONVECTION STEAMER**  
Manual 1177893 (03/10) \$18.00

Congratulations! You have purchased one of the finest pieces of heavy-duty commercial cooking equipment on the market.

You will find that your new equipment, like all Southbend equipment, has been designed and manufactured to meet the toughest standards in the industry. Each piece of Southbend equipment is carefully engineered and designs are verified through laboratory tests and field installations. With proper care and field maintenance, you will experience years of reliable, trouble-free operation. **For best results, read this manual carefully.**

RETAIN THIS MANUAL FOR FUTURE REFERENCE.

TABLE OF CONTENTS:

Safety Precautions.....	2
Specifications.....	3
Installation.....	4-9
Operation.....	10-11
Cooking Times/Hints.....	11-13
Maintenance.....	14-15
Adjustments/Troubleshooting.....	16
Parts/Accessories.....	17
Warranty.....	18

LOCATION AND IDENTIFICATION OF NAME PLATE

The serial plate with voltage, model, and serial information is located on the right hand side of the steamer cavity on the upper rear corner. On single units a second tag is located on the face of the door which will show only model and serial number. On Tandem units a second tag is located on the left side of the left unit and the right side of the right unit.

Read these instructions carefully before attempting installation. "Installation" and "Start Up" should be performed by a qualified installer. Unless the installation instructions for the above-described Southbend product are followed and performed by a qualified service technician (a person experienced in and knowledgeable of the installation of commercial gas and/or electrical, and water specifications for cooking equipment) then the terms and conditions of the Manufacturer's Limited Warranty will be rendered void and no warranty of any kind shall apply.

In the event you have questions concerning the installation, use, care, or service of the product, write to the Technical Service Department, Southbend, 1100 Old Honeycutt Rd., Fuquay-Varina, North Carolina 27526.

**NOTICE**

This product is intended for commercial use only; not for household use.

**IMMEDIATELY INSPECT FOR SHIPPING DAMAGE**

All containers should be examined for damage before and during unloading. The freight carrier has assumed responsibility for its safe transit and delivery. If damaged equipment is received, either apparent or concealed, a claim must be made with the delivering carrier.

- A) Apparent damage or loss must be noted on the freight bill at the time of delivery. The freight bill must then be signed by the carrier representative (Driver). If the bill is not signed, the carrier may refuse the claim. The carrier can supply the necessary forms.
- B) A request for inspection must be made to the carrier within 15 days if there is concealed damage or loss that is not apparent until after the equipment is uncrated. The carrier should arrange an inspection. Be certain to hold all contents plus all packing material.



1100 Old Honeycutt Road • Fuquay Varina, NC 27526  
(919) 552-9161 • (800) 348-2558  
FAX (800) 910-9915 • FAX (919) 552-8682

# SAFETY PRECAUTIONS

Before installing and operating this equipment, be sure everyone involved in its operation is fully trained and aware of precautions. Accidents and problems can be caused by failure to follow fundamental rules and precautions.

The following symbols, found throughout this manual, alert you to potentially dangerous conditions to the operator, service personnel, or to the equipment.

 **DANGER**

This symbol warns of immediate hazards which will result in severe injury or death.

 **WARNING**

This symbol refers to a potential hazard or unsafe practice which could result in injury or death.

 **CAUTION**

This symbol refers to a potential hazard or unsafe practice which could result in injury, product, or property damage.

**NOTICE**

This symbol refers to information that needs special attention or must be fully understood, even though not dangerous.

 **WARNING  
FIRE HAZARD**

For your safety, do not store or use gasoline or other flammable vapors and liquids in the vicinity of this or any other appliance.

Keep area around appliances free and clear from combustibles.

 **WARNING  
SHOCK HAZARD**

- Do not open panels that require the use of tools.
- Stand back when opening doors - hot steam or hot water may escape from steamer.
- Unit must be cleaned daily and properly maintained to reduce chances of unsafe operating conditions.

 **WARNING  
BURN HAZARD**

Watch for clogged drain - can create burn hazard when door is opened.

**NOTICE**

Be sure the Operator's Manual and important papers are given to the proper authority.

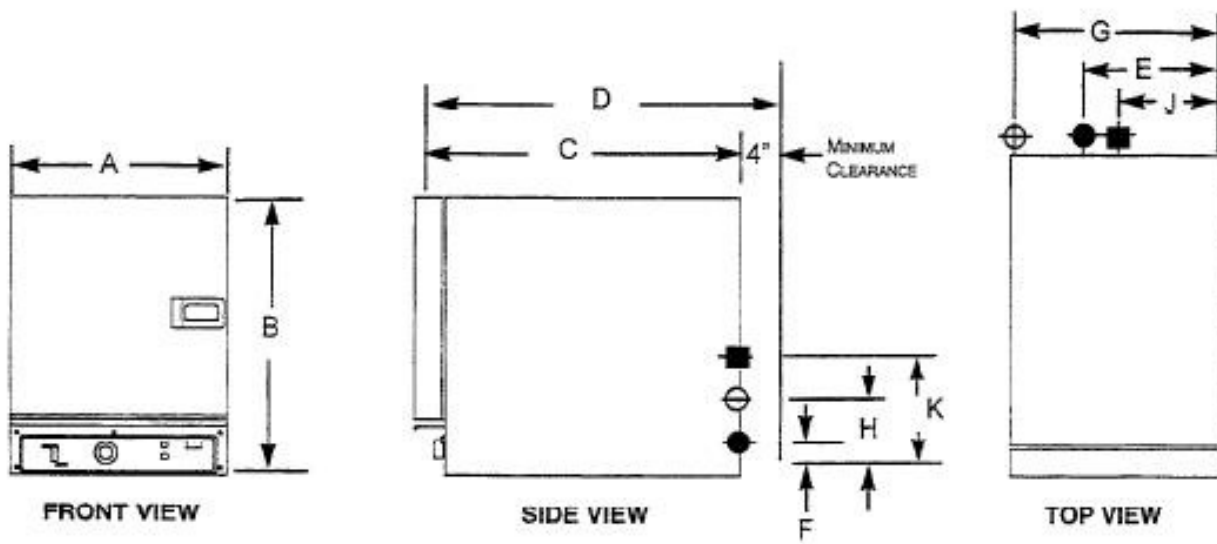

- ⊞ Electric connection - terminal block
- ⊕ Drain 1/4" o.d., leave open, do not connect to floor drain
- ⊖ Cold water inlet 1/4", 30 p.s.i. min.-60 p.s.i. max.

**DIMENSIONS:**

( ) = Millimeters

MODEL	Width A	Height B	DEPTH		DRAIN		WATER		ELECT CONN		CRATE SIZE			Cubic Volume	Crated Weight
			C	D	E	F	G	H	J	K	Width	Depth	Height		
R2	16" (406)	21" (533)	24 3/8" (625)	28 3/8" (727)	8 1/2" (216)	1 1/4" (32)	14 3/8" (365)	1 1/4" (32)	4 3/4" (121)	1" (25)	19 1/2" (499)	31 1/2" (800)	25 1/2" (724)	10.13cf .29 cm	112# 51 kg

Internal Dimensions: 13 1/2 W x 22 D x 12 1/2 H

**UTILITY INFORMATION: ELECTRIC:** One electric connection per unit is required.

SINGLE UNIT TOTAL CONNECTED AMPS	MAX. AMPS PER LINE	
	1 PHASE	3 PHASE
208 V 60 Hz	44	25
220 V 50/60 Hz	41	24
240 V 60 Hz	38	22
380/220 V 50 Hz	24	14
415/240 V 50 Hz	22	13
480 V 60 Hz	19	11

**WATER USAGE AT TIMED OR MANUAL COOKING:**

0.46 total gallons per minute at 45 p.e.i.

**IMPORTANT: UNIT MUST BE LEVEL FOR PROPER OPERATION. WARRANTY WILL BE VOIDED FOR IMPROPER INSTALLATION.**

\*All units shipped per customer order, three phase or single phase. If necessary to change see installation section for conversion.

*Circuit must be wired for maximum amps at required voltage.*

<b>WATER SPECIFICATIONS:</b>	
To meet warranty requirements, supply water must be as follows:	
Connection:	1/4" cold water
Pressure:	30 to 60 PSI
Total Dissolved Solids (TDS):	60 PPM
Hardness:	2 grains or 35 PPM
PH Factor:	7.0 to 7.5

**NOTICE**

Floor drain must be located outside the confines of the equipment base.

**NOTICE**

Southbend reserves the right to change specifications and product design without notice. Such revisions do not entitle the buyer to corresponding changes, improvements, additions, or replacements for previously purchased equipment.

**NOTICE**

These procedures must be followed by qualified personnel or warranty will be voided.

**GENERAL:**

**NOTICE**

The unit, when installed, must be electrically grounded and comply with local codes, or in the absence of local codes with the National Electrical Code ANSI/NFPA 70-latest edition.

Canadian installation must comply with CSA-Standard (C22.2 No. 109-M1981 General Requirements-Canadian Electrical Code, Part II. 109-M1981) Commercial Cooking Appliances.

## ELECTRICAL CONNECTION:

Electrical diagrams are located inside right compartment on back side of right side cover. Be sure that the input voltage and phase match the requirements shown on the serial plate. A positive ground connection is essential.

### ELECTRICAL:

A field connection Terminal Block is located at the rear of the unit, lower left side. A hole is provided for a 3/4" conduit fitting (solid or flex). Refer to figure 1.

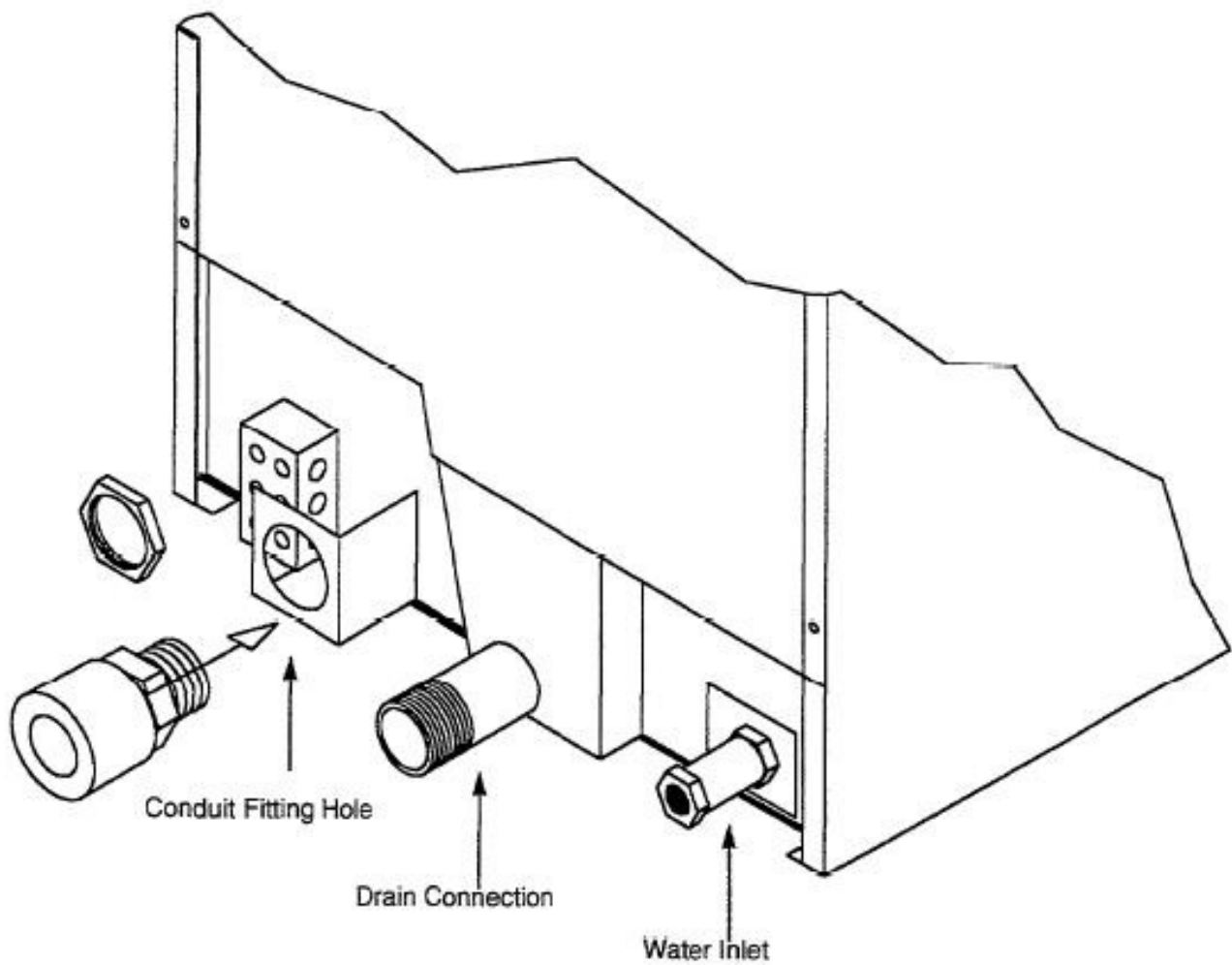

FIGURE 1

**NOTE:** This unit has one power supply for controls and elements, as well as one ground wire. A POSITIVE GROUND CONNECTION IS ESSENTIAL.

DO NOT ALLOW ANY TAMPERING OR ADJUSTMENT OF ANY CONTROL OR WIRING. THE UNIT IS FACTORY SET. ADJUSTMENT OF ANY INTERNAL COMPONENT OTHER THAN THE FIELD TERMINAL BLOCK CAN VOID THE WARRANTY.

**ELECTRICAL CONNECTION NOTE:**

All 208-220-240 and 480 volt units will have three terminal block sections, "L1-L2-L3," for use with either 3-wire 3-phase or 2-wire, single-phase, 50 or 60 Hz.

All 380V and 415V units will have four terminal block sections, "L1-L2-L3-N," for use with European style 4-wire 3-phase with neutral.

**THREE PHASE TO SINGLE PHASE CONNECTION:**

Be sure that the input voltage matches the requirement on the serial plate. The unit is factory wired per customer order. If necessary to change phase, remove control panel, item "A" in figure 2, and rearrange element lead wires 2 and 3 as shown below.

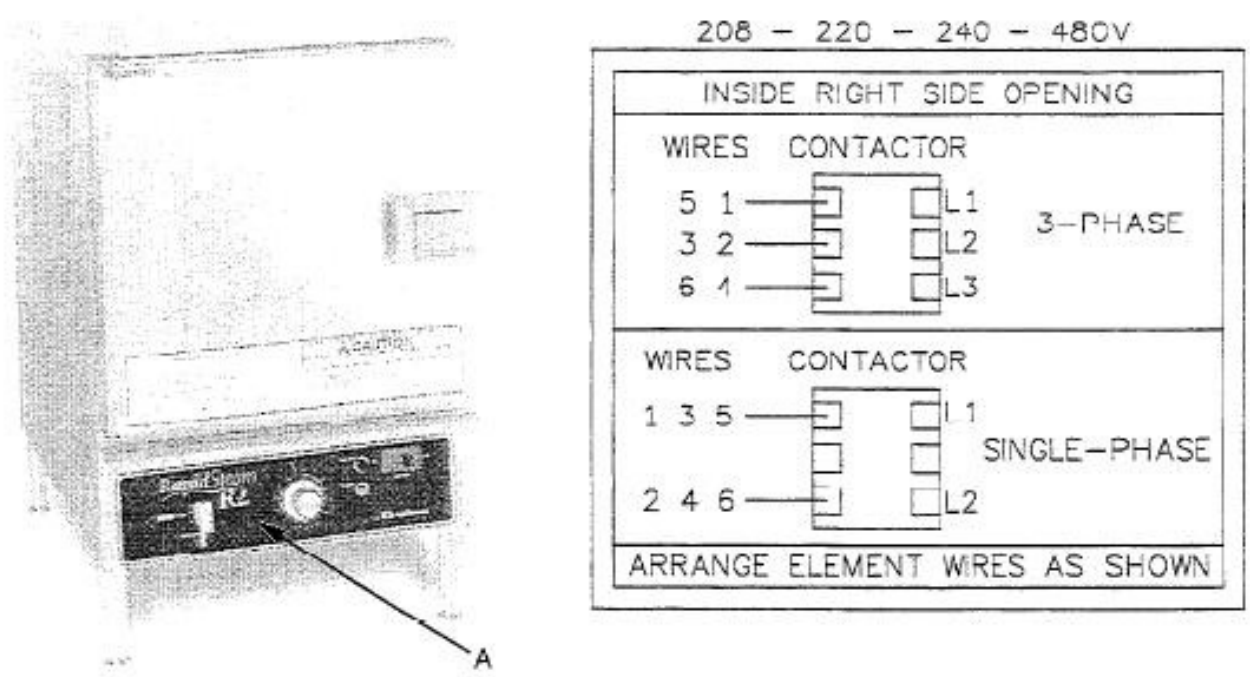

**FIGURE 2**

**WATER CONNECTION:**

Connect cold water line, 1/4" (6mm) NPT into female side of strainer located at right lower side of unit as you face the back of the steamer.

Water line pressure should be 30 psi (205 kpa) minimum to 60 psi (410 kpa) maximum.

**NOTE:** To facilitate cleaning, and allow access to rear of unit, flexible connections are recommended.

Recommended Plumbing:

(Furnished by Installer)

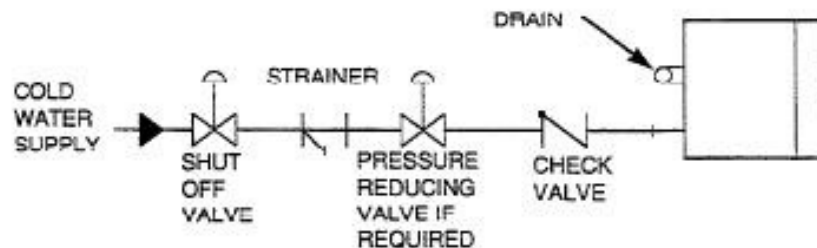

**⚠ WARNING**

Do not connect steamer to a hot water hose. A hot water connection will damage the steamer.



## WATER SPECIFICATION:

To meet warranty requirements, supply water must meet the following specification:

Pressure:	30 to 60 psi
Total Dissolved Solids (TDS):	60 PPM
Hardness:	2 Grains or 35 PPM
pH Factor:	7.0 to 7.5

## DRAIN LINE:

The drain line connection size from the unit is 1" NPT (32 mm). Position the unit near, but not on top of, an open floor drain. DO NOT directly plumb to the unit unless you also install an "open funnel" downstream of this connection in the drain system. Make the drain line from the unit to the air gap above the "open funnel" as short as possible. There should be no horizontal piping between the unit and the air gap above the "open funnel." The "open funnel" is intended to eliminate any water from entering the steamer because of a blocked drain and it also prevents any back pressure within the steamer cavity. The unit must be free-venting to the atmosphere. Any connection that allows the build-up of back pressure in the unit such as a reduction in pipe size to a line smaller than 1" or a 90 degree angle in the line prior to the "open funnel" drain discharge point may cause personal or property damage and therefore will void the warranty. This is a pressureless, free-venting steam cooker and will not operate properly unless the drain line is short, at a steep angle, and open! See figure 3.

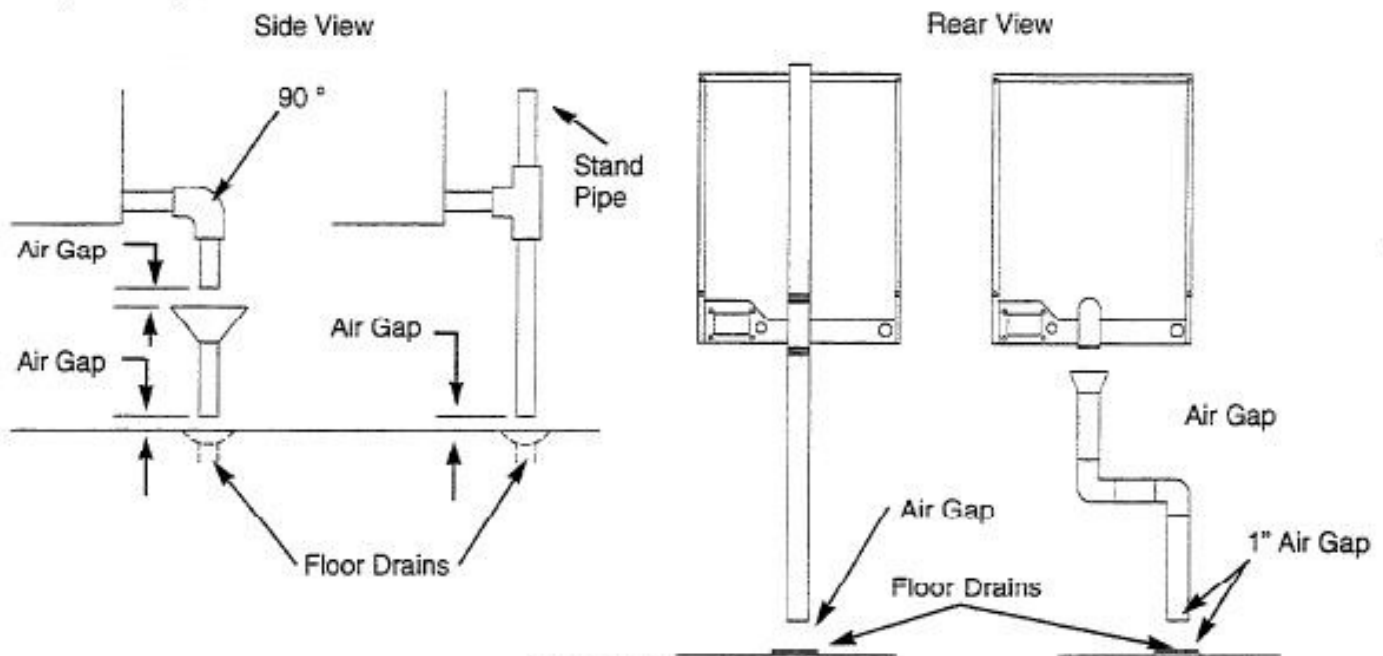

FIGURE 3

### **WARNING** **BURN HAZARD**

It is imperative that the drain connection be installed per instructions and kept clean (open) to assure free venting to atmosphere. A clogged drain will cause pressure to build up inside the steamer cavity and can endanger the operator when opening the door. It will also cause excessive leakage of steam from the door.

### **NOTICE**

Floor drain must be located outside the confines of the equipment base or damage to equipment may occur.

Do not locate unit adjacent to any high heat or grease producing piece of equipment, such as a range top, griddle, fryer, etc., that could allow radiant heat to raise the exterior temperature of the steam body above 130°F (54°C).

DO NOT MOUNT ABOVE OTHER COOKING EQUIPMENT.



### NOTICE

Local codes regarding installation vary greatly from one area to another. The National Fire Protection Association, Inc. states in its NFPA 96 latest edition that local codes are "authority having jurisdiction" when it comes to installation requirements for equipment. Therefore, installations should comply with all local codes.

**EXHAUST FANS AND CANOPIES:** It is recommended that the steamer be installed under a ventilation hood. Consult local codes for proper installation of hoods.

### LEVELING:

Unit must be level to assure maximum performance. Improper leveling may void warranty.

### NOTICE

Proper ventilation is the owner's responsibility. Any problem due to improper ventilation will not be covered by warranty.

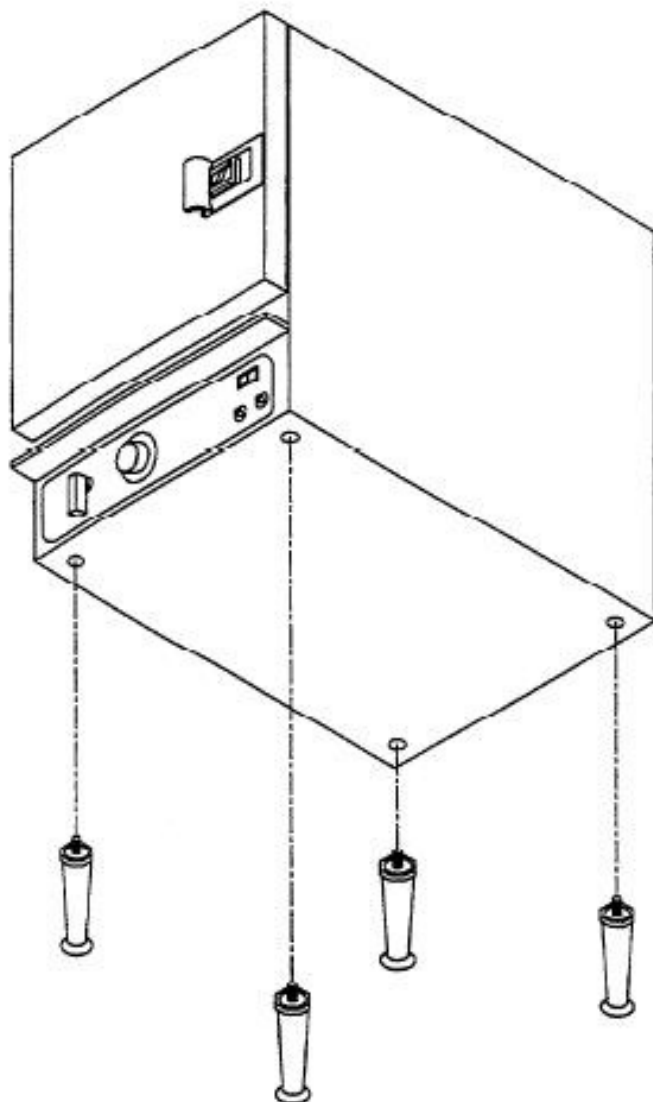
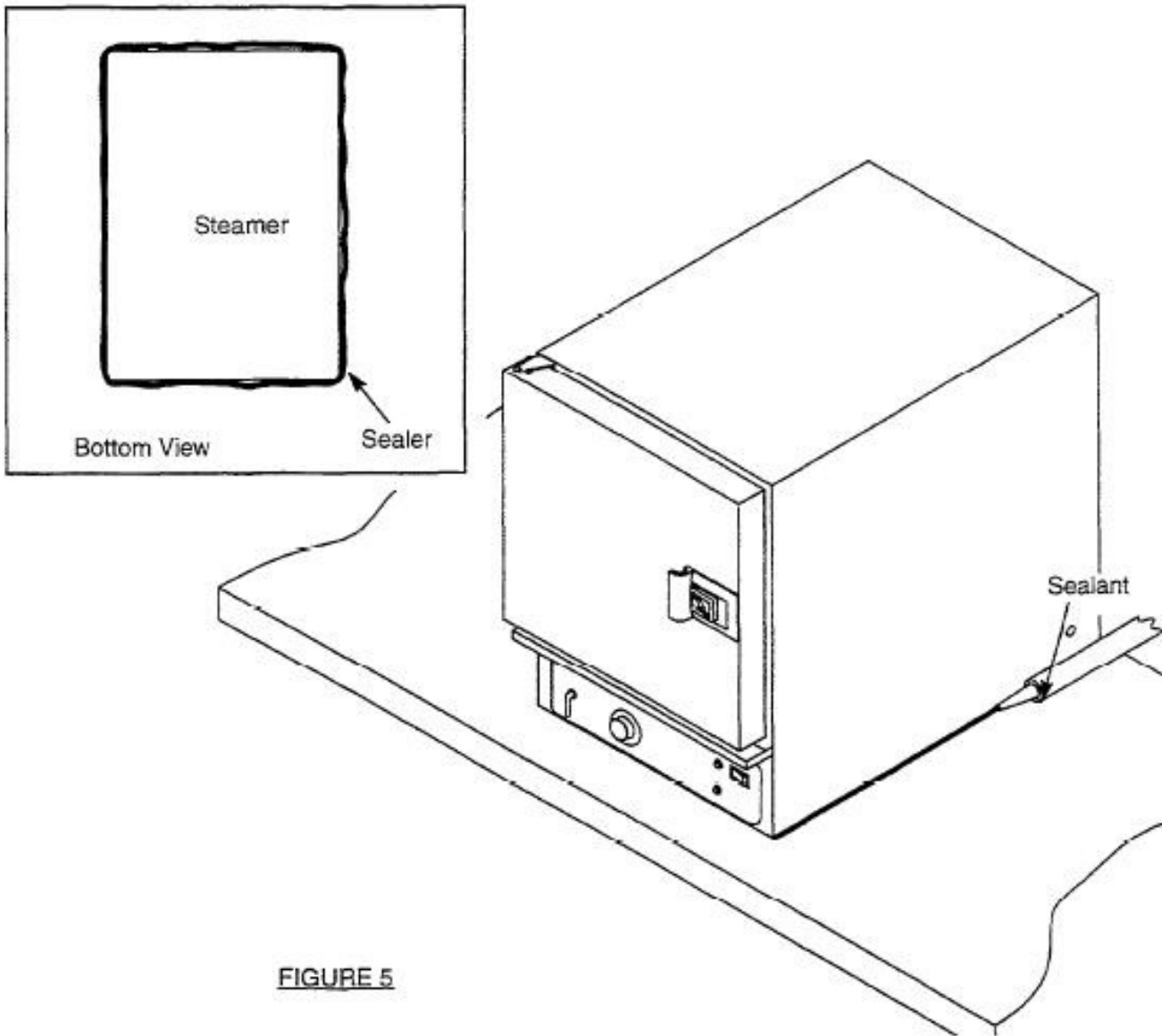

FIGURE 4

### TO INSTALL:

1. Uncrate carefully. Report any hidden damage to the freight carrier IMMEDIATELY.
2. Do not remove any tags or labels until unit is installed and working properly.
3. If unit is to be installed on legs, locate legs and install as shown on drawing. (See Figure 4.)

4. If unit is to be installed on a counter top or other surface without using legs, the unit must be sealed to the surface to prevent any water, grease, etc. from accumulating under the steamer. The steamer can be bolted to the counter but will still have to be sealed. The installer may use G.E. or DOW CORNING RTV type sealant. (Consult local code for exact requirements.) See figure 5.



**FIGURE 5**

## **PERFORMANCE CHECK:**

The following items should be checked within the first 30 days of operation by a qualified service technician.

1. Check doors for proper alignment.
2. Check door gaskets for wear and sealing ability.
3. Check spray tubes or nozzles for cleanliness and/or leakage.
4. Check all gauges, timers, valves and switches for proper operation.
5. Visually check control compartment wiring for burned or loose connections.
6. Check electrical load on elements for proper wattage.
7. Be sure operators understand the importance of proper cleaning and maintenance.

# THEORY OF OPERATION

Compared to other steam cookers with complicated boilers, the R2 is a very simple machine. Immersion elements are installed on the left side of the cavity and when water covers the elements, water starts to boil and turn to steam. There is no pressure in this unit.

The SteamMaster R2 is designed to provide quick heat-up from a cold start.

All equipment must be installed correctly to ensure proper operation and reliable service. Installation instructions must be followed by a qualified technician.

Before you turn the unit on, be sure that you have: POWER to unit, WATER to unit, and an OPEN DRAIN.

## CONTROL OPERATIONS

### START UP:

1. **Close** the drain valve (turn lever to the run position.).
2. Turn power switch on. Unit will fill and begin heating. Unit will be up to operating temperature, ready to use, in approximately ten (10) minutes. The "Ready" light will light up when the unit is ready to use.

### NORMAL OPERATION:

2. "Manual" – This unit runs full-power continuously.

### NORMAL OPERATION:

#### REVIEW —

- Use timer as desired, put in "Manual" position to disable buzzer. Timer has no impact on operation.
- To conserve water and electricity during "slow" periods, shut unit off, **do not** open drain valve.

### SHUTOFF:

Turn power switch "Off." Turn the drain valve lever to "DRAIN".

### OPERATING INSTRUCTIONS:

1. De-Lime Indicator Light – The "De-Lime" indicator light will illuminate when the unit senses that the elements need cleaning. Usually a thin layer of deposits are present when this occurs. When the light signaling the operator that cleaning/de-liming should be performed, see "Maintenance, Periodic Cleaning" under service section for recommended procedures.
2. Cleaning must be performed to restore normal operation of the unit. When the "DE-LIME" light comes on, the contactor shuts off power to the elements.

 **WARNING  
BURN HAZARD**

When door is being opened, hot steam or hot water may escape from steamer. Stand back when opening door.

## SUGGESTED COOKING TIMES:

Timer settings are for general guidance only. Differences in food quality, size, shape, freshness, load size and degree of doneness desired must be considered and adjustments made in time if necessary.

PRODUCT	WEIGHT	PORTIONS	COOKING TIME (Minutes)	PAN USED
<b>Asparagus</b>				
Fresh	3½ lbs.	14 (4 oz.)	8-10	Full/Perforated
Frozen Spears (Thawed)	5 lbs.	20 (4 oz.)	9	Full/Perforated
<b>Beans</b>				
Green – Frozen, Cut	5 lbs.	20 (4 oz.)	12	Full/Perforated
Green – Fresh	5 lbs.	20 (4 oz.)	15-17	Full/Perforated
Wax – Frozen	5 lbs.	20 (4 oz.)	13	Full/Perforated
Lima – Frozen	5 lbs.	20 (4 oz.)	10	Full/Perforated
<b>Broccoli</b>				
Spears – Fresh	4 lbs.	16 (4 oz.)	10-12	Full/Perforated
Spears – Frozen (Thawed)	5 lbs.	20 (4 oz.)	8	Full/Perforated
<b>Brussel Sprouts</b>				
Fresh	5 lbs.	20 (4 oz.)	15-17	Full/Perforated
Fresh	5 lbs.	20 (4 oz.)	13	Full/Perforated
<b>Carrots</b>				
Frozen – Whole Baby	5 lbs.	20 (4 oz.)	12	Full/Perforated
Fresh – ¼-Inch Dias Cut	5 lbs.	20 (4 oz.)	12	Full/Perforated
<b>Cabbage</b>				
Green, Cut Into Wedges		24	15	Full/Perforated
Red, Cut Into Wedges		16	18-20	Full/Perforated
<b>Cauliflower</b>				
Fresh, Whole	2 lbs.	8 (4 oz.)	9-10	Full/Perforated
Fresh, Whole	2 lbs. 12 oz.	11 (4 oz.)	15	Full/Perforated
Frozen, Flowerettes	5 lbs.	20 (4 oz.)	10-12	Full/Perforated
<b>Corn</b>				
Fresh, Cob, 4-5 Inch Ears	5½ lbs.	15	13-15	Full/Perforated
Frozen – Whole Kernel	5 lbs.	20 (4 oz.)	8	Full/Perforated
Frozen – Cob, 6 Inch Ears	9 lbs.	14	12-14	Full/Perforated
<b>Mixed Vegetables</b>				
Frozen	5 lbs.	20 (4 oz.)	12	Full/Perforated
<b>Peas</b>				
Frozen	5 lbs.	20 (4 oz.)	8	Full/Perforated
<b>Potatoes</b>				
Red Bliss – Whole	7 lbs.	28	35	Full/Perforated
Russetts – Whole	8 lbs.	20	23-25	Full/Perforated
Russetts – Peeled	5 lbs.	12	20	Full/Perforated
Russetts 1-Inch Cubes	5 lbs.	20 (4 oz.)	17	Full/Perforated
<b>Spinach</b>				
Fresh, Leaf	2½ lbs.	10 (4 oz.)	5	Full/Perforated
Frozen, Chopped	6 lbs.	24 (4 oz.)	35	Full/Perforated
<b>Zucchini</b>				
Fresh – Slices ¼-Inch Thick	5 lbs.	20 (4 oz.)	6-8	Full/Perforated
<b>Eggs</b>				
Large – Hard Cooked	12 lbs.	12	15-16	½ Perforated

PRODUCT	WEIGHT	PORTIONS	COOKING TIME (Minutes)	PAN USED
<b>Meats</b>				
Comed Beef	6½ lbs.	18 (6 oz.)	2 hours	Full
Hot Dogs, Thawed	5 lbs.	40 (2 oz.)	5	Full/Perforated
Hot Dogs, Frozen	5 lbs.	40 (2 oz.)	10	Full/Perforated
<b>Fowl</b>				
Boneless Chicken Breast	4½ lbs.	12 (6 oz.)	15	Full/Perforated
Tamales, Frozen	3 lbs.	12 (4 oz.)	20	Full/Perforated
Tortilla, Frozen 8-Inch	4 Tortillas	4	45 Seconds	Half/Perforated
Beef Ravioli, Frozen	48 Ravioli (1 lb. 8 oz.)	8	5-6	Full/Perforated
Elbow Macaroni	2 lbs. Uncooked	32 (2 oz.)	7	In Perforated Pan Nested in Solid Pan
Spaghetti	2 lbs. Uncooked	32 (2 oz.)	14	In 4-Inch Full/Perforated
Egg Noodles	2 lbs. Uncooked	32 (2 oz.)	10	Full/Perforated
Converted Rice	2 lbs. 2½ Qts. Water + Oil & Salt		25	Full/Perforated
Navy Beans	2 lbs.			Full/Perforated
Place beans in pan and cover with 3-quarts hot tap water. Steam for 2 minutes; remove from steamer and cover for 1 hour. Remove cover and place back in steamer for 40 minutes.				
Black Eyed Peas	2 lbs.			Full/Perforated
Place peas in pan and cover with 3-quarts hot tap water. Steam for 2 minutes; remove from steamer and cover for 1 hour. Remove cover and place back in steamer for 35 minutes.				
<b>Seafood</b>				
Oysters	5 lbs.	16 Count	12	Perforated Pan Nested in a Full Pan 2½-Inch Deep
Shrimp, Fresh, Medium, Heads Removed	5 lbs.		6-7	Full/Perforated
Shrimp, Frozen, Large, Peeled & Deveined	5 lbs.		8	Full/Perforated
Lobster	1¾ lbs.		8	Full/Perforated
Alaskan King Crab Legs	1 lb.		4-5	Full/Perforated
Cherry Stone Clams	5 lbs.	12	7	Full/Perforated
Fish Fillets	7½ lbs.	12 (10 oz.)	18	Full/Perforated Nested in Full Hotel Pan

**END USER TIPS:**

Schedule cooking of fresh vegetables so that they will be served soon after they are cooked. If it is necessary to prepare them in advance, they can be plunged into cold water, drained thoroughly and held under refrigeration until needed for service.

Five pounds of cold cooked vegetables can be reheated in the steamer in 5 to 10 minutes, depending upon the variety.

Adding salt to the water for eggs cooked in the shell makes the cooking water more efficient and faster at its job. If the egg cracks, the white is cooked at the crack and is sealed right away.

To avoid green yolk (which is a deposit of iron sulfide) chill the eggs immediately after removing from the steamer by plunging them into a cold water bath (preferably containing ice).

A quick and easy way to cook eggs for a salad mixture is to crack them directly into a solid steam table pan which has been lightly coated with salad oil. *Do not mix.* Steam until they are hard cooked. Remove and chop as you would for egg salad. The job of peeling has been eliminated.

Transfer steamed hot chicken to deep pan, cover with Cacciatore Sauce and finish in oven. Bake 20 to 30 minutes. May be held on steam table.

After steaming, chicken, sausage, and fish may be browned in Infra-Red or Radiant Broiler. Brush with melted margarine mixed with salad oil to give a golden brown color.

Use juice saved from steamed chicken or turkey to make soups, sauces, or casserole dishes.

Chicken may be steamed in advance and held under refrigeration for next day's use. Be sure to bring product back to 180°F before serving.

Save the juice from the corned beef. After the cabbage has been steamed, place it in a solid pan and add the juice for flavoring and holding on a steam table.

Steaming brisket is a definite time saver. Boiling in water takes 40 to 50 minutes per pound. Using the R2 can save 50% in cooking time.

Cabbage, when steamed, retains its color and wedge identity. It will not break apart as it does when boiled in an open pot.

When removing items prepared in a perforated pan, put a solid pan underneath the perforated pan to hold the pan of cooked food. This will prevent dripping on the floor.

The R2 is designed to accept standard 12 x 20 pans. Fractional size pans and dishes can be used as well with the optional perforated shelf.

For stirring, the pan does not have to be removed from the steamer. Pull pan 1/3 way out of the cavity and the entire surface is accessible.

The door may be opened at any time during operation to remove or add food.



# MAINTENANCE

Southbend equipment is sturdily constructed of the best quality materials and is designed to provide durable service when treated with ordinary care. To expect the best performance, your equipment must be maintained in good condition and cleaned daily. Naturally, the periods for this care and cleaning depend on the amount and degree of usage.

Following daily and periodic maintenance procedures will increase the life of your equipment. Climatic conditions – salt air – seasonings – water quality – may require more thorough and frequent cleaning or the life of the equipment could be adversely affected.

## DAILY CLEANING

### YOUR R2 MUST BE THOROUGHLY CLEANED EVERYDAY.

- Remove the pan supports and well cover. Wash separately in a sink with a mild detergent and warm water. Dry thoroughly with a clean cloth. Scotch Brite scouring pads may be used for baked-on deposits.
- Wash interior surfaces, including the heating elements with a mild detergent and warm water. Rinse with clean water. Dry thoroughly with a clean cloth. If discoloration starts due to build up of seasonings or food products, remove by using Scotch-Brite scouring pad. Then wash, rinse, and dry as above.
- Wash floats carefully, check that float stems are clean and floats move freely.
- Wipe exterior surface with a clean damp cloth.
- Return all cleaned parts to the unit, placing in their proper position.
- LEAVE THE DOOR OPEN AT NIGHT AFTER CLEANING. This allows the unit to dry thoroughly after cleaning and also prolongs the life of the door gasket.

## PERIODIC CLEANING – AS REQUIRED:

If a lime or mineral deposit starts to build up in the interior, this should be cleaned by using Southbend “descaler” or other non-caustic deliming solution. Follow manufacturer’s recommended procedures. Thoroughly rinse out unit.

To remove food build up or discoloration, apply cleanser to a damp cloth or sponge and rub cleanser on the material in the direction of the polishing lines on the metal. Never rub with a circular motion. Soil and discoloration which do not respond to the above procedure can usually be removed by rubbing the surface with Scotch-Brite scouring pads.



### CAUTION

DO NOT GET WATER IN THE CONTROLS. Could result in expensive repairs or electrical shock.

DO NOT USE ordinary steel wool as any particles left on the surface will rust. NEVER USE a wire brush, steel or abrasive scouring pads, scraper, file or other steel tools. Surfaces which are marred collect dirt more rapidly and become more difficult to clean. Marring also increases the possibility of corrosive attack.

DO NOT clean door gasket with a high chlorine solution or bleach.

NEVER USE A CORROSIVE CLEANER. USE ONLY CLEANERS APPROVED FOR STAINLESS STEEL.

**STAINLESS STEEL:** To remove normal dirt, grease, or product residue from stainless steel, use ordinary soap and water (with or without detergent) applied with a sponge or cloth. Dry thoroughly with a clean cloth. Never use vinegar or any corrosive cleaner.

To remove grease and food splatter or condensed vapors that have baked on the equipment, apply cleanser to a damp cloth or sponge and rub cleanser on the metal in the direction of the polishing lines on the metal. Rubbing cleanser as gently as possible in the direction of the polished lines will not mar the finish of the stainless steel. NEVER RUB WITH A CIRCULAR MOTION. Soil and burnt deposits which do not respond to the above procedure can usually be removed by rubbing the surface with SCOTCH-BRITE scouring pads. DO NOT USE ORDINARY STEEL WOOL, as any particles left on the surface will rust and further spoil the appearance of the finish. NEVER USE A WIRE BRUSH, STEEL SCOURING PAD, SCRAPER, FILE OR OTHER STEEL TOOLS. Surfaces which are marred collect dirt more rapidly and become more difficult to clean. Marring also increases the possibility of corrosive attack. Refinishing may then be required.

# MAINTENANCE

 **WARNING**  
**BURN HAZARD**

For proper and safe operation, this steamer must be cleaned daily. Be sure the overflow pipe is not clogged before operating. A clogged pipe could cause too much hot water to enter the steamer thereby creating a BURN HAZARD when the door is being opened. Clean this steamer daily as described in this manual. Failure to do so could result in serious injury or damage. Drains must be kept clean and clear of debris.

 **WARNING**  
**SHOCK HAZARD**

De-energize all power to equipment before cleaning the equipment.

 **CAUTION**

DO NOT USE ordinary steel wool as any particles left on the surface will rust.

NEVER USE a wirebrush, steel or abrasive scouring pad, scraper, file or other steel tools.

Surfaces which are marred collect dirt more rapidly and become more difficult to clean. Marring also increases the possibility of corrosive attack.

DO NOT clean door gasket with a high chlorine solution or bleach.

NEVER use any corrosive cleaner. Use only cleaners approved for stainless steel.

 **WARNING**

Improper cleaning can result in expensive repairs or electrical shock. Do not get water on electrical controls or motors.

# ADJUSTMENTS

## NOTICE

Service work should be performed only by a qualified technician who is experienced in, and knowledgeable of, the operation of commercial gas, electric, and steam cooking equipment. Contact the Authorized Service Agency for reliable service, dependable advice or other assistance, and for genuine factory parts.

Warranty will be void and the manufacturer is relieved of all liability if:

(A) Service work is performed by other than a qualified technician.

OR

(B) Other than genuine Southbend replacement parts are installed.

## TROUBLE SHOOTING GUIDE

<i>Symptom:</i>	<i>Check or Replace:</i>
No power	Check circuit breaker
No water	Check water supply
Heating elements will only operate for brief regular cycles and delime light is illuminated.	Clean and delime steamer

SERVICE

## **WARNING SHOCK HAZARD**

De-energize all power to equipment before servicing the equipment.

At least twice a year, have your Southbend Authorized Service Agency or another qualified service technician clean and adjust the unit for maximum performance.

Consult the Southbend Authorized Parts/Service Distributor list for the Authorized Service Representative in your area. If this is not available, call the Service Department at Southbend, 1-800-348-2558 for their name and number.

# PARTS -- ACCESSORIES



## NOTICE

INSTALLATION OF OTHER THAN GENUINE SOUTHBEND PARTS WILL VOID THE WARRANTY ON THIS EQUIPMENT.

The serial plate with voltage, model, and serial information is located on the right side of the steamer cavity on the upper rear corner. On single units a second tag is located on the face of the door which will show only model and serial number. On Tandem units, a second tag is on the right side of the right unit and the left side of the left unit.

Replacement parts may be ordered either through a Southbend Authorized Parts Distributor or a Southbend Authorized Service Agency.

When ordering parts, please supply the Model Number, Serial Number, Part Number, Description, Finish, and Electrical Characteristics as applicable.

For parts not listed, consult a Southbend Authorized Parts Distributor or Southbend Authorized Service Agency. Consult the Southbend Authorized Parts/Service Distributor list for the Authorized Parts supplier in your area. If this list is not available, call the Service Department at Southbend, 1-800-348-2558 for same.

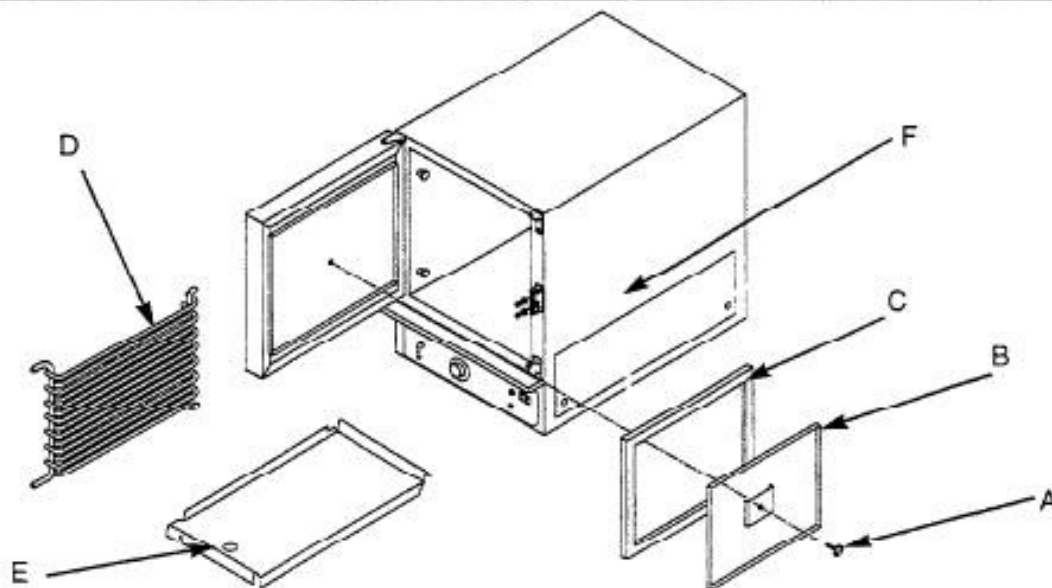

FIGURE 6

ITEM	PART NO.	DESCRIPTION
A	1173224	Screw 1/4 – 20 x 5/8 5 OT
B	1173195	Retainer Panel Assembly
C	1177072	Door Gasket
D	1174587	Cavity, Side Rack
E	1178268	Well Cover Deflector
F	1177080	Door Striker
*	4460002	Technical Manual
*	1176561	Cleaning Instructions
*	PM-162	Cleaning Pad
*	4450020	SteamMaster descaler 24 pack
*	4450021	SteamMaster Descaler Master Pack (Contains 8 of the 4450020)

## **NO QUIBBLE WARRANTY**

- ☑ If a customer calls with a problem involving any Southbend product, we will rectify it, **no charge**: 24 hours a day, 7 days a week, 365 days a year.
- ☑ Our "No Quibble" Warranty means there will be no charge to the customer for the call, parts, travel or for premium time. If the problem turns out that the unit is unplugged, the circuit breaker is tripped, the gas is shut off, or even if the customer doesn't know how to operate the equipment, etc.,—it's covered.

***The foregoing warranty is exclusive and in lieu of all other warranties, expressed or implied. There are no implied warranties of merchantability or of fitness for a particular purpose.***

- ☑ Southbend, hereinafter referred to as the seller, warrants equipment manufactured by it to be free from defects in material and workmanship for which it is responsible. The seller's obligation under this warranty shall be limited to replacing or repairing such part. Such warranty shall be limited to the original purchaser only and shall be effective for a period of one year from date of original installation or 18 months from date of purchase, whichever is earlier, provided that the terms of payment have been fully met.
- ☑ Normal maintenance functions, including lubrication, cleaning or customer abuse are not covered by this No Quibble Warranty.
- ☑ The seller shall be responsible only for repairs or replacements of defective parts performed by seller's authorized service personnel. Authorized service agencies are located in principle cities throughout the contiguous United States and Hawaii. This warranty is valid in the United States and is void elsewhere unless the product is purchased through Middleby International with warranty included.
- ☑ The foregoing shall be the seller's sole and exclusive obligation and the buyer's sole and exclusive remedy for any action including breach of contract or negligence. In no event shall the seller be liable for a sum in excess of the purchase price of the item. The seller shall not be liable for any prospective or lost profits of the buyer.
- ☑ This warranty is effective on Southbend equipment sold on, or after **Feb. 15, 1996**.



*First in Cooking, Built to Last.*

# **southbend**

1100 Old Honeycutt Road  
Fuquay-Varina, NC 27526

☎ (919) 552-9161  
FAX (919) 552-8682

**Rapid Steam**  
R3

Consult the Southbend Authorized Parts/Service Distributor list  
for the Authorized Service Representative in your area.

If this list is not available, call the Service Department at Southbend, 1-800-348-2558, ext. 400 or 401



## **SOUTHBEND LIMITED WARRANTY**

Southbend warrants that the equipment, as supplied by the factory to the original purchasers, is free from defects in materials and workmanship. Should any part thereof become defective as a result of normal use within the period and limits defined below, then at the option of Southbend such parts will be repaired or replaced by Southbend or its Authorized Service Agency. This warranty is subject to the following conditions:

If upon inspection by Southbend or its Authorized Service Agency it is determined that this equipment has not been used in an appropriate manner, has been modified, has not been properly maintained, or has been subject to misuse or misapplication, neglect, abuse, accident, damage during transit or delivery, fire, flood, riot or Act of God, then this warranty shall be void.

Specifically excluded under this warranty are claims relating to installation; examples are improper utility connections and improper utilities supply. Claims relating to normal care and maintenance are also excluded; examples are calibration of controls and adjustments to pilots and burners.

Equipment failure caused by inadequate water quality is not covered under warranty. WATER QUALITY must not exceed the following limits: Total Dissolved Solids (TDS) – 60 PPM (Parts Per Million). Hardness – 2 Grains or 35 PPM. PH Factor – 7.0 to 7.5. Water pressure 30 PSI minimum, 60 PSI maximum. Boiler maintenance is the responsibility of the owner and is not covered by warranty.

This equipment is intended for commercial use only. Warranty is void if equipment is installed in other than commercial application.

Repairs under this warranty are to be performed only by a Southbend Authorized Service Agency. Southbend cannot be responsible for charges incurred from other than Authorized Southbend Agencies.

**THIS WARRANTY MUST BE SHOWN TO AN AUTHORIZED SERVICE AGENCY WHEN REQUESTING IN-WARRANTY SERVICE WORK. THE AUTHORIZED SERVICE AGENCY MAY AT HIS OPTION REQUIRE PROOF OF PURCHASE.**

This warranty does not cover services performed at overtime or premium labor rates nor does Southbend assume any liability for extended delays in replacing or repairing any items in the equipment beyond the control of Southbend. "Southbend shall not be liable for consequential or special damages of any nature that may arise in connection with such product or part." Should service be required at times which normally involve overtime or premium labor rates, the owner shall be charged for the difference between normal service rates and such premium rates.

In all circumstances, a maximum of one hundred miles in travel and two and one half hours (2.5) travel time shall be allowable. In all cases, the closest Southbend Authorized Agency must be used.

The actual warranty time periods and exceptions are as follows:

This warranty only covers product shipped into the 48 contiguous United States and Hawaii, one-year labor, one-year parts effective from the date of original purchase. There will be no labor coverage for equipment located on any island not connected by roadway to the mainland.

Exceptions to standard warranty, effective within above limitations:

Glass Windows, Door Seals, Rubber Seals, Light Bulbs, Ceramic Bricks,

Sight Glasses, Cathodic Descalers or Anodes.....90 days material and labor

Stainless Steel Fry Pot..... 4 years extended material warranty on fry pot only — no labor

Stainless Steel Open Top Burners..... 4 years extended material warranty on burners only — no labor

Pressure Steam Boiler Shell..... Prorated 4 years extended warranty on boiler shell only — no labor

*Boiler shells which have not been properly maintained will not be covered by warranty.*

In all cases, parts covered by a five-year warranty will be shipped FOB the factory after the first year.

Our warranty on all replacement parts which are replaced in the field by our Authorized Service Agencies will be limited to three months on labor, six months on materials (parts) effective from the date of installation. See LIMITED WARRANTY – REPLACEMENT PARTS for conditions and limitations.

If the equipment has been changed, altered, modified or repaired by other than a qualified service technician during or after the one-year limited warranty period, then the manufacturer shall not be liable for any damages to any person or to any property which may result from the use of the equipment thereafter.

**"THE FOREGOING WARRANTY IS IN LIEU OF ANY AND ALL OTHER WARRANTIES EXPRESSED OR IMPLIED INCLUDING ANY IMPLIED WARRANTY OF MERCHANTABILITY OR FITNESS, AND CONSTITUTES THE ENTIRE LIABILITY OF SOUTHBEND. IN NO EVENT DOES THE LIMITED WARRANTY EXTEND BEYOND THE DURATION OF ONE YEAR FROM THE EFFECTIVE DATE OF SAID "WARRANTY."**





A product with the Southbend name incorporates the best in durability and low maintenance. We all recognize however, that replacement parts and occasional professional service may be necessary to extend the useful life of this unit. When service is needed, contact a Southbend Authorized Service Agency, or your dealer. To avoid confusion; always refer to the model number, serial number, and type of your unit.

**Southbend**  
1100 Old Honeycutt Road  
Fuquay-Varina, NC 27526  
(800) 348-2558 · (919) 552-9161  
FAX (800) 348-2558 · (919) 552-8682  
<http://www.middleby.com>